



ANNIVERSARY
1987-2022

ESOTERIC

... Start Revolution?



Revolution Begins

In the dead silence of the “Esoteric MagneDrive System”
you will hear the sounds of a revolution taking place,
making history for vinyl playback.



35th
ANNIVERSARY
1987-2022



**A new undertaking to commemorate
the 35th Anniversary of the Esoteric legacy;**

it's the first-ever turntable in our history, the Grandioso T1.

Accommodating a patent-registered unique contact-free drive mechanism,
the "Esoteric MagneDrive System", that inductively synchronizes
the rotations

of a magnetic driver and platter, realizing a quiet and silky-smooth rotation
at an extraordinarily accurate rotation speed.



Grandioso T1

Analog Turntable

Key Features

- Esoteric's patented contact-free drive system "Esoteric MagneDrive System"
- Magne-Float platter greatly reduces spindle bearing friction by reducing platter's effective mass from 19kg down to approx. 4kg.
- Consists of 3 separated units: main unit, motor unit, and power supply unit.
- High quality VCXO motor driver ensures precise platter rotation.
- 10MHz Clock Sync capability with the Grandioso G1X Master Clock.
- Inverted bearing system supports smooth rotation of the platter.
- The Micrometer knob on the front panel provides fine-tuning capability of sonic characteristics, by adjusting the strength of magnetic force being applied from the magnetic driver to the platter.
- Triple layer chassis made of Aluminum and wood, effectively controls vibration.
- The mid-chassis is applied with beautiful high gross piano lacquer.
- The isolation feet have a special damping mechanism that eliminates external vibration.
- Two speed control (33/45 rpm), adjustable with 0.1% order.
- The T1 is offered with TA-9D dynamic balance tonearm, or without tonearm configuration.
- Optional arm-board allows the T1 accommodates up to 3 tonearms.

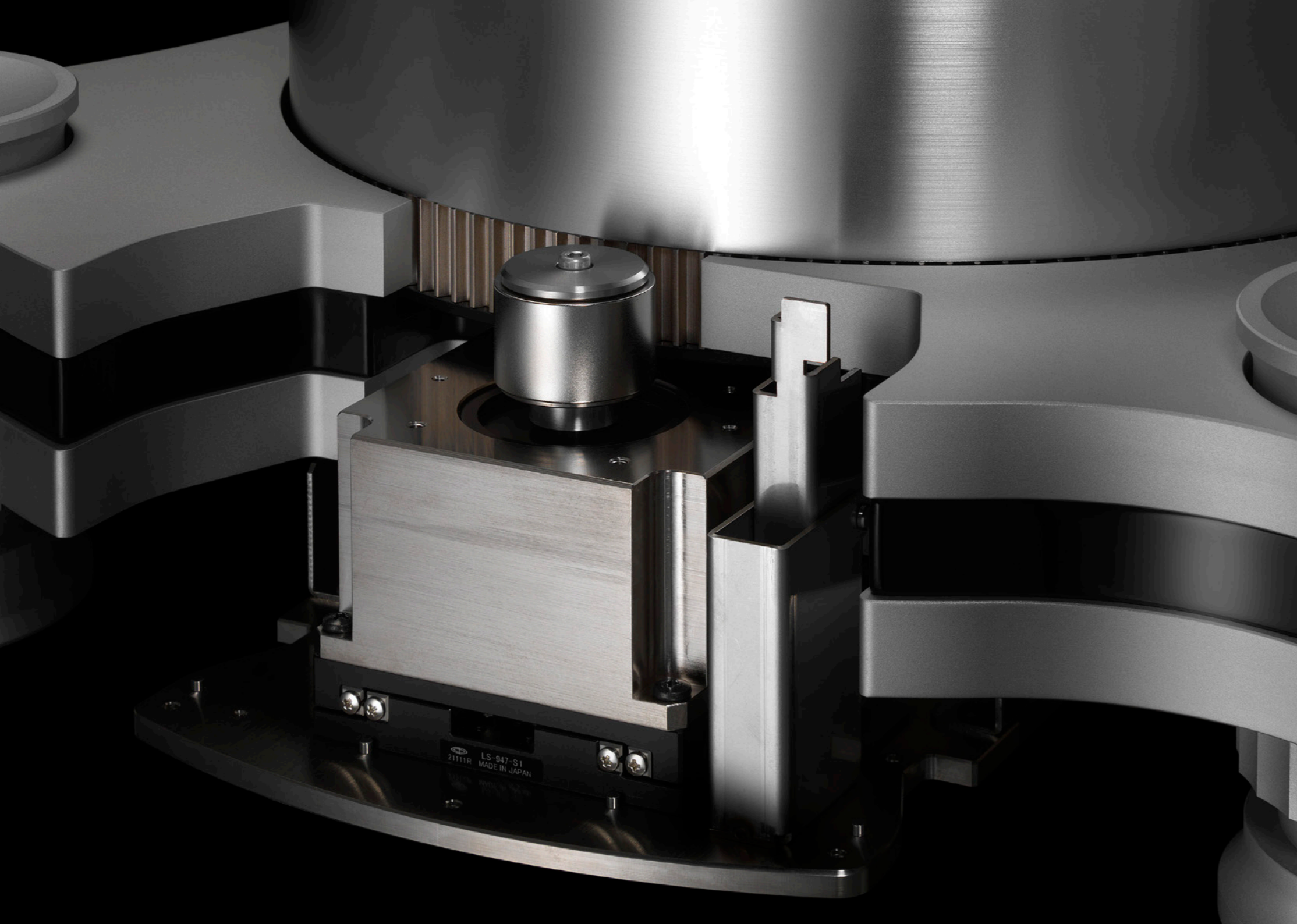

ESOTERIC MagneDrive System Japan Patent No. 6501130

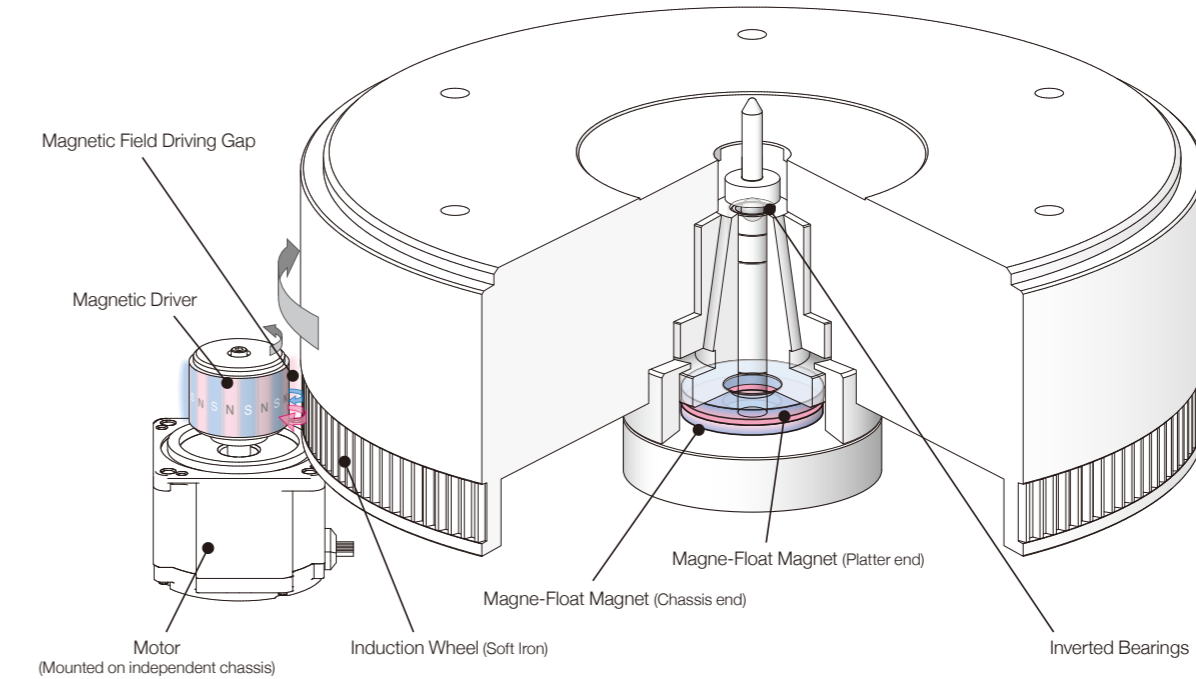

The Esoteric MagneDrive System (Japan Patent No. 6501130) is a non-contact turntable drive system employing magnetic force for rotation.

In order to achieve the philosophy of “Realization of Master Sound in analog playback”, it took more than five years from the start of the project to the acquisition of the patent and its commercialization.

A “Magnetic Driver” shaped like an idler is mounted at the end of the drive motor. Its sides are magnetized so that the S and N poles are aligned alternately.

The platter itself is non-magnetic aluminum, but a soft-iron “Induction Wheel” shaped like a strobe is mounted on the bottom of the side opposite the driver and is magnetized. As the magnetic driver rotates near the turntable, the platters to rotate synchronously, smoothly, and without contact, thanks to magnetic force.

The principle of rotational operation by magnet and teeth

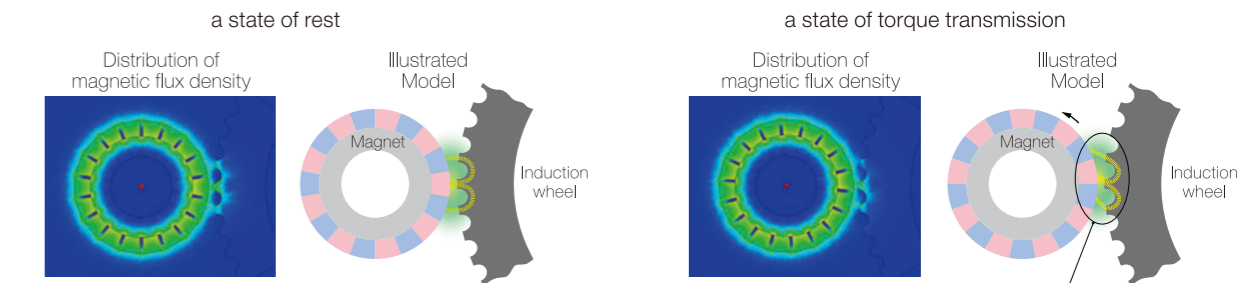

The position shown in the above is stable and becomes stationary. (The yellow dashed line is the magnetic flux)

The magnetic flux forms the shortest magnetic path through this curvature. The magnetic flux tries to form the shortest magnetic path through this curved section. As the magnet rotates, the magnetic flux flowing through the wheel tries to return to the stable point, causing the wheel to rotate. This is the transmitted torque.



ESOTERIC MagneDrive System Japan Patent No. 6501130

Extremely quiet rotation

For vinyl record playback, which picks up vibrations from record grooves on the order of microns and converts them into audio signals, the elimination of vibrations generated by motors is essential for master sound reproduction. The Esoteric MagneDrive System is free from motor vibration by making the power transmission from the motor to the platter non-contact, thus obtaining a crystal clear sound.

Platter with Magne-Float system

The platter is a high-mass design of 19kg machined from aluminum block. The Magne-Float system reduces the load on the bearing to approximately 4kg, and contributes to quiet rotation by achieving both silky-smooth rotation with high rotational inertia and reduced friction level in an ideal manner. In addition, inverted bearings are employed to bring the fulcrum of the platter closer to the surface of the vinyl disc and increase the stability of rotation. The platter surface, which is focused on beautiful appearance, is carefully finished one-by-one by skilled craftsmen in the final process to increase surface smoothness and create a beautiful spin pattern that resembles craftwork.

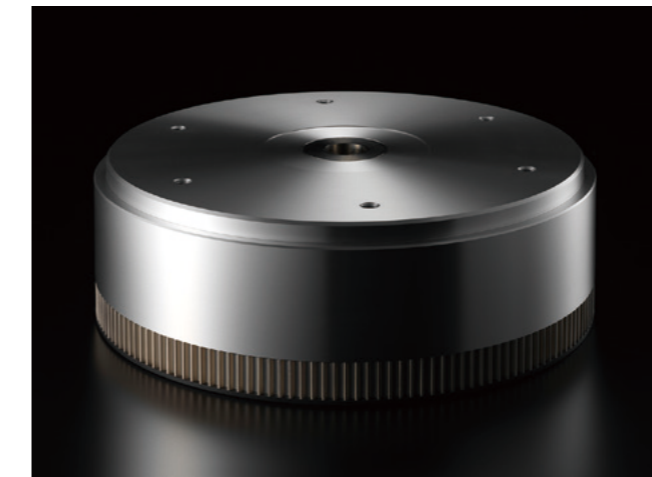

Accurate synchronous rotation

Along with the non-contact vibration isolation, one of the greatest advantages of the MagneDrive mechanism is the precise rotational accuracy of the platter. Magnetic driver and platter, – these two components, like two gears of different sizes, always rotate precisely in a constant ratio. As long as magnetic synchronization is maintained, there are no speed fluctuations and no factors that can cause speed deviations, such as belt stretch, idler or pulley mechanical accuracy, and so on.

Since this mechanism follows the one and only law of physics “reduction ratio” (gear ratio in gears) of the two components, the platter maintains a constant and accurate speed of rotation in any conditions. To maximize this beauty of the mechanism, the rotation speed is regulated by directly controlling the current waveform of the motor with a high-precision processor, instead of using a conventional servo to correct the platter rotation, resulting in a natural sound free from the fluctuation that is often associated with loop correction.

ESOTERIC MagneDrive System Japan Patent No. 6501130



A motor unit incorporating the best of Esoteric technology

The motor unit, which controls the precise rotation of the magnetic driver, is the culmination of Esoteric's accumulated mechanical and circuit engineering expertise. The motor unit is isolated from the main unit and thoroughly controlled by mounting on a heavyweight 6mm-thick brass bottom chassis. The motor driver circuit uses a high-precision 10MHz clock to accurately generate the drive waveforms that drive the motors. Furthermore, by supplying extremely pure DC from an independent power supply unit, the transmission of unwanted vibrations to the motor unit is minimized.



10MHz master clock sync ready

The motor unit is equipped with an external 10MHz clock input. Sound quality can be further upgraded by connecting the Grandioso G1X master clock generator (sold separately) to supply a higher precision clock to the motor driver.

Drive torque adjustment by micrometer

Direct drive, idler drive, and belt drive... The MagneDrive system is the ideal drive mechanism that combines the advantages of direct/idler drive, with its powerful and accurate pitch, while maintains smooth rotation of belt drive, and flexibility in tone adjustment on top of these advantages.

By turning the micrometer dial on the front of the motor unit, the distance between the motor driver and platter (transmission torque) can be changed to adjust the sound to your preference, from powerful to soft tones, while listening to music.



Relation between distance and drive torque

Since magnetic force is inversely proportional to the square of the distance, a very small change in distance can drastically change the transmission torque. When the driver and platter are farthest apart (+1.0mm), the torque is reduced to -57%, and the transmission torque can be changed precisely and freely while playing with the micrometer dial.

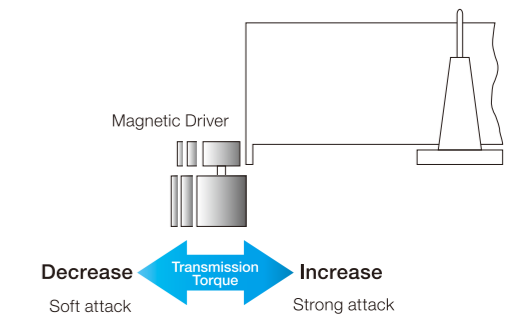

More advantages...

Unlike other turntable mechanisms, the MagneDrive system eliminates replacement of a drive belt, and minimizes maintenance thanks to reduced wear-out parts, making ensure long-lasting high quality sound.



Grandioso G1X
Master Clock Generator

Grandioso T1
Analog Turntable





Elegance in Performance

3-layer chassis made of aluminum and wood

The gracefully curved, fascinating chassis is the culmination of Esoteric's tradition of mechanical engineering. A triple layer of wood sandwiched between thick aluminum layers is employed.

The tone arm is mounted on the top layer, and the spindle assembly and isolation feet are mounted on the bottom layer. A wood layer (mid-chassis) with high internal loss is configured in between them to prevent mutual vibration transmission between the tone arm and platter, resulting in a crystal clear sound quality.

The wooden mid-chassis not only isolates vibration, but also gives the T1 the ability to express music with excellent tonal balance, reminiscent of the original master tapes, thanks to the rich mid and low frequency range of the material.

Beautiful high gloss piano finish mid chassis

The wooden mid-chassis has a high-gloss piano finish that has undergone multiple layers of painting and polishing processes. We wanted the highest level of texture befitting an innovative turntable. The surface is as smooth as wet, a glossy, jet-black luster without glare. Organic as if crafted, the depth of its appearance contrasts dynamically with the functional, industrial aluminum layers of modern architecture, further enhancing the pleasure of owning the T1.

Toward the one and only our design goal of "Reproducing the Master Sound," the T1 chassis optimally controls all vibrations that affect sound quality.

The T1 chassis is mechanically engineered like an F1 racing car, with the balance between rigidity and flexibility pushed to the limit.

The elegant and clean form is a testament to its high degree of perfection.

Isolation foot with special damper structure

Esoteric's isolation foot employs a hybrid structure of coil springs and special damper resin, which is extremely effective for very low frequencies and has a short damping time (approximately 0.5 seconds), providing extremely superior vibration isolation capability, while a conventional floating turntable

with a coil spring system is very effective in blocking very low frequencies that cause feedback, but it takes a certain amount of time for vibration damping.

Characteristic of the Hybrid Isolation Foot

Damping Time

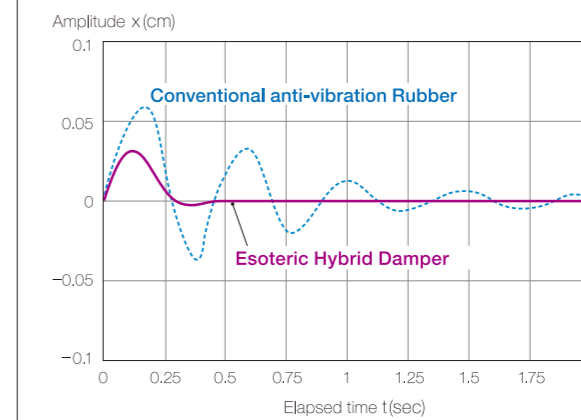

The Esoteric hybrid damper stops vibration after a damping time of about 0.5 seconds (about half cycle amplitude).

Vibration transmission rate

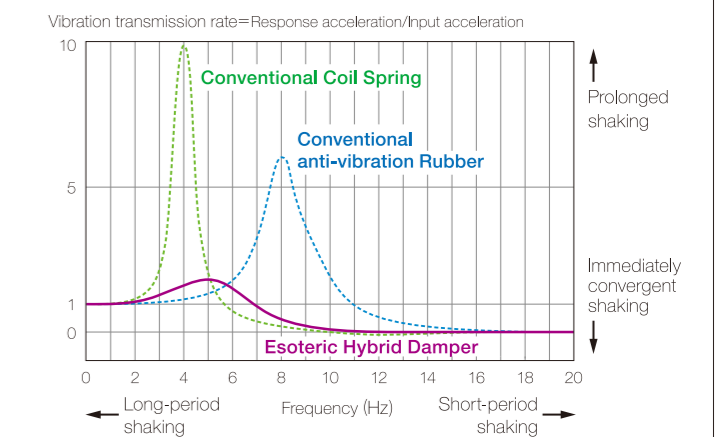

While conventional coil springs and rubber dampers have difficulty absorbing vibration at certain frequencies (speed of vibration) and linger for a long time, Esoteric hybrid dampers can easily absorb and converge vibration for a wide range of shaking.

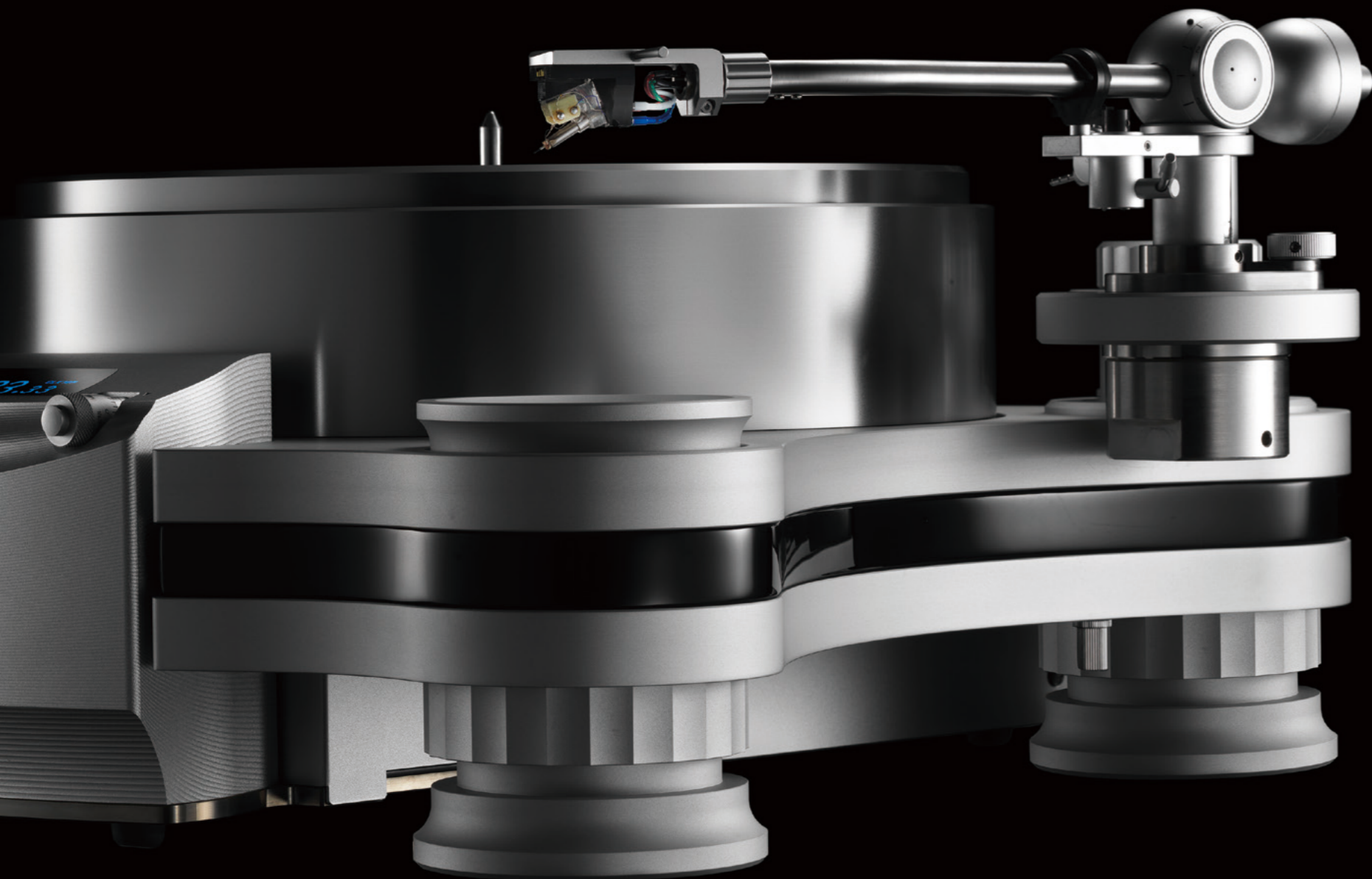

**Equipped with dynamic balanced tone arm TA-9D.
Armless configuration is available.**

The TA-9D is based on IKEDA Sound Labs' IT-345, which is in the vein of Fidelity Research's famous FR-64 that has been highly acclaimed worldwide since the heyday of analog audio.

The TA-9D employs a dynamic balance system that is resistant to eccentricity and warping of records and enables stable reading. The dynamic balance system has a low center of gravity and a thick core tone, while the stainless steel tone arm pipe inlaid with brass and aluminum increases rigidity and

optimize vibration modes. Internal wiring is made of 6N (99.9999%) + 4N high-purity hybrid copper wire, and the VTA elevation allows the height of the arm (VTA) to be adjusted while playing back records.

T1 is also available in armless (AL) configuration, so that customers can choose arms of their own choice. In addition, up to three arms* can be added with the optional arm base kit.



* The TA-9D can have up to two additional arms (maximum of two arms), excluding the arm post on the front left side. The position of the arm post and the number of arms to be added may be restricted depending on the shape of the arm mounting area, etc. Please contact our distributors if you wish to add other arms.

Power supply unit for motor

The power supply unit for the motor is isolated from the motor and supplies extremely clean and powerful current. A dedicated over-sized toroidal power transformer is accommodated in a separated unit. The power supply for the operation is driven by an R-core power transformer separate from that for the motor. The enclosure, which requires rigidity, is made of aluminum and is thoroughly non-resonant, while, the top panel, which needs to be free of vibration for an open sound, has a semi-floating structure, and the isolation feet with a special structure reduce mechanical stress and improves sound quality.



Turntable Sheet

The turntable sheet is selected from a variety of materials after extensive listening tests in order to eliminate any coloration of the T1's tone and to pursue a function to protect the precious vinyl disc surface from scratches. In combination with the T1, a sheet of "WASHI", a traditional Japanese paper material with the most neutral tone is employed.



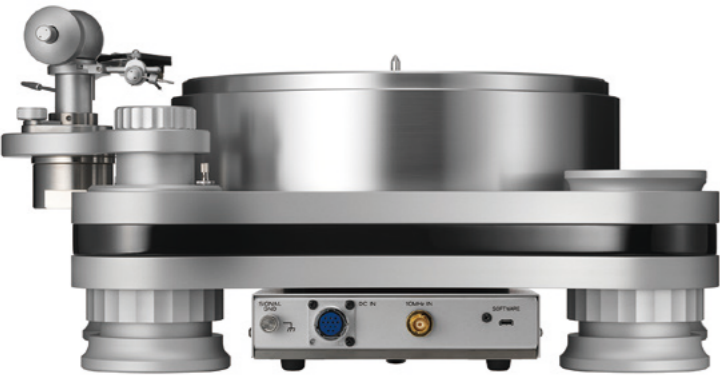

Overall Dimensions (unit: mm/inch)

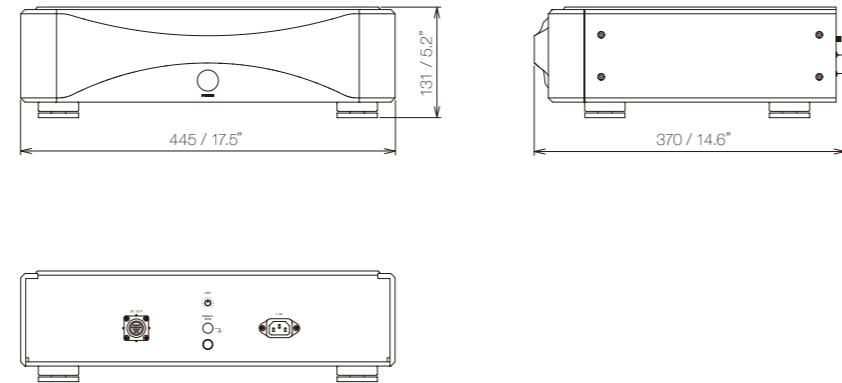
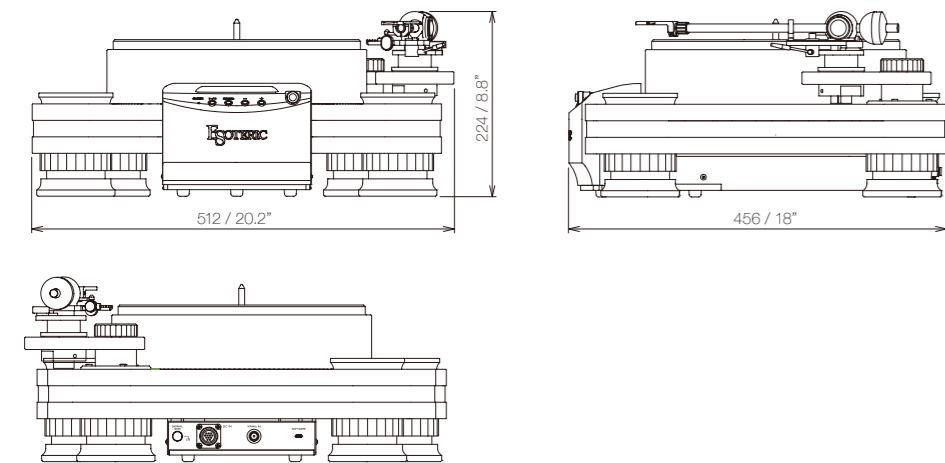

Foot positions (unit: mm/inch)

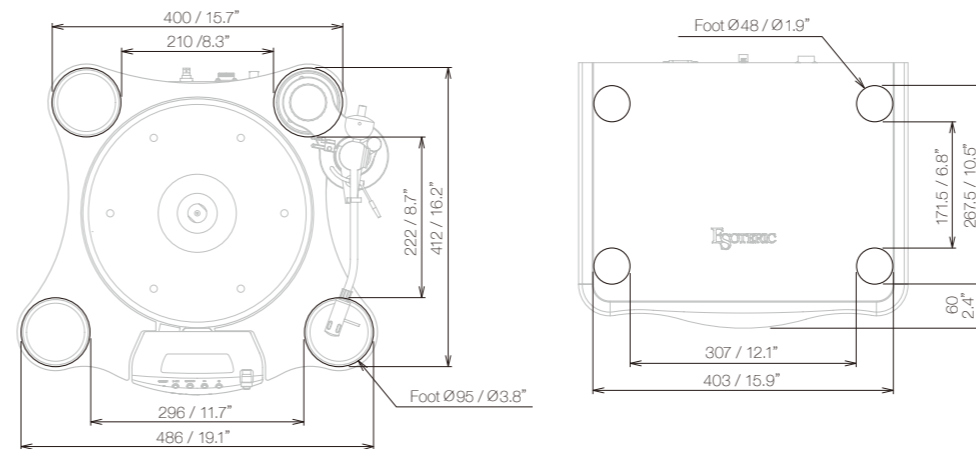

Specifications

Turntable section

Rotation speed:	33 1/3rpm / 45rpm
Rotation speed adjustment range:	±12% (0.1% step)
Wow and flutters:	0.06% or less (W.R.M.S)

Clock input

Connector:	BNCx1
Inout impedance:	50Ω
Input frequency:	10MHz (±10ppm)
Input level:	0.5 to 1.0Vrms (sine wave)

Tonearm section (TA-9D)

Type:	Dynamic balance
Overall length:	326mm
Effective length:	245mm
Distance between tonearm axis to spindle:	230mm
Overhang:	15±2mm
Tracking error:	+2° to 1° 21'
Needle pressure range:	0 to 5g (0.25g step)
VTAElevation range:	0 to 10mm
Cartridge/shell balance range:	6 to 38.5g
Headshell weight:	16.45g

Base unit

Dimensions (WxHxD):	497x215x436mm*
Weight:	17 kg

Platter

Dimensions (diameter x height):	Ø315.4x103mm
Weight:	19kg

Motor unit

Dimension (WxHxD):	180x137x450mm*
Weight:	9kg

Power supply unit

Dimensions (WxHxD):	445x131x370mm*
Weight:	18kg

General

Power:	120V AC 60Hz 220V AC 50Hz
Power consumption:	8W
Standby power consumption:	0.4W

*including protrusions

Please note that not all models are available in every country. Design and specifications subject to change without notice. ©2022 ESOTERIC COMPANY. All Rights Reserved. All text, images, graphics and other materials on this brochure are subject to the copyright and other intellectual property rights of ESOTERIC COMPANY. These materials shall not directly or indirectly be published, reproduced, modified or distributed in any medium. ESOTERIC is a trademark of TEAC Corporation, registered in the U.S. and other countries. Grandioso is a trademark of TEAC Corporation. All other brand or product names are trademarks or registered trademarks of their respective holders.

ESOTERIC COMPANY

1-47, Ochiai, Tama-shi, Tokyo JAPAN 208-8530
<https://www.esoteric.jp/en>





Revolution continues...





ESOTERIC

